

GRADE 10

MEET & GREET

IAA School

Counseling



Helping Students By:

- Overcoming social or behavioral problems through individual and group counseling.
- Setting realistic social/emotional and academic goals and developing a plan to achieve them.
- Working with students to develop skills such as organization, time management, and effective study habits.

Mr. Charbel - A through F
c.salamoun@iaa.edu.jo

Ms. Kendal - G through Z
k.jackson@iaa.edu.jo

Working As A Team To:

- Help 6th Graders adjust to Secondary.
- Check-in with New IAA Students.
- Train and support IAA Peer Helpers.
- Facilitate PSHE lessons, such as:
 - Social Skills
 - Transitioning to University
- Refer students and parents to additional resources outside of school.

رسالة الدين الإسلامي

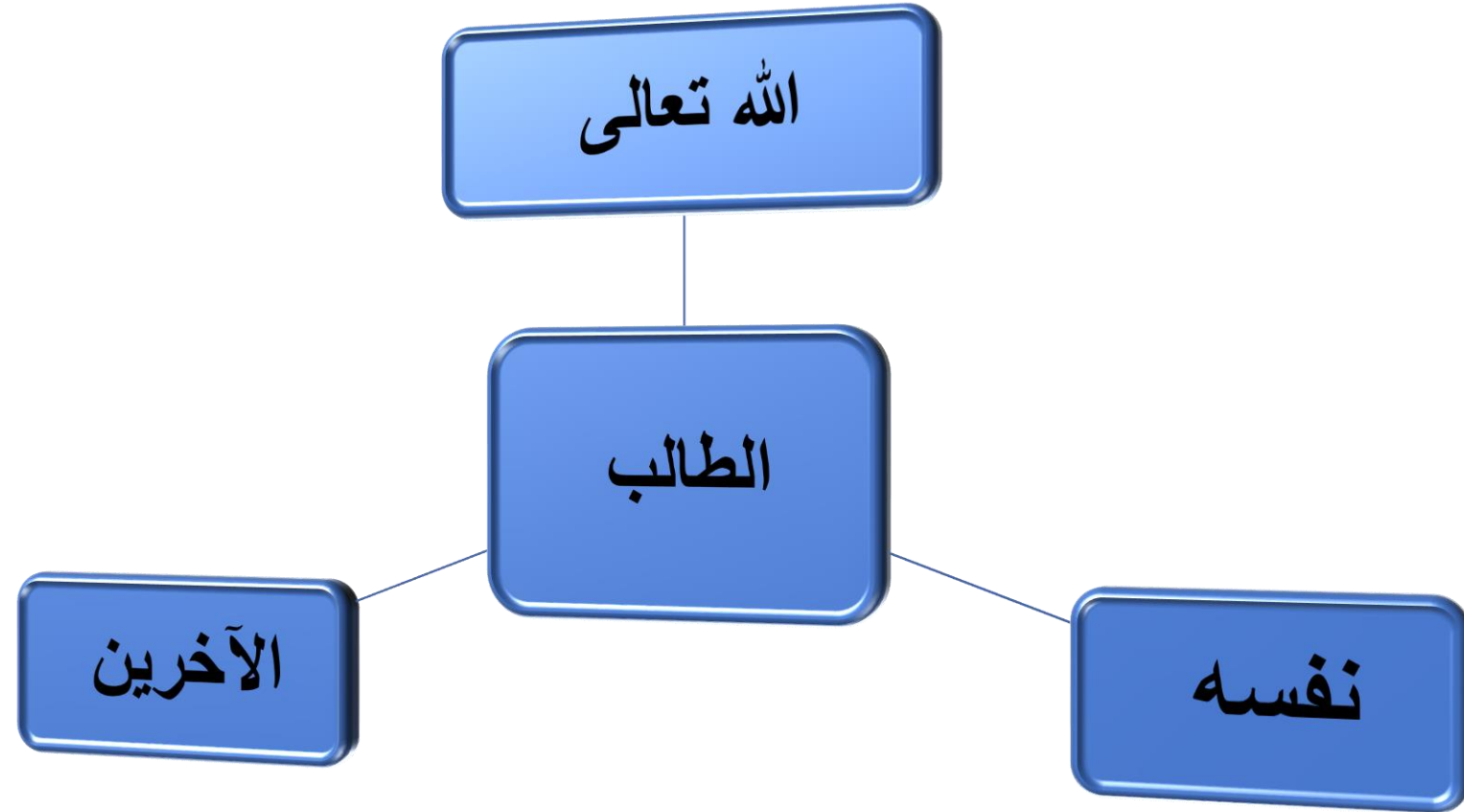

MYP
Physical & Health Education

Health related to Fitness

Anatomy, energy systems and Physical abilities

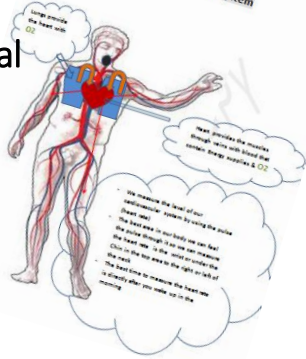

PHE G10 / Eyad Makanai

PHE
MYP Grade Boundaries

Grade Boundaries	
1	0-5
2	6-9
3	10-14
4	15-18
5	19-23
6	24-27
7	28-32

MYP
Physical & Health Education

Basketball



- Content index**
- **Basketball rules and regulations**
 - Definitions
 - Equipment's
 - Teams
 - Captains: duties and power
 - Coaches: duties and power
 - Playing time
 - Status of ball
 - Goal: When made and its value
 - Throw in
 - Timeout
 - Substitution
 - **Basketball Strategies**
 - Zone Defense
 - Man to Man Defense

Content index

- **General Rules:**
 - For single matches
- **Service rules in badminton**
- **The steps of executing the forehand service**
 - Step one (preparation position)
 - Step two (executing position)
 - Step three (follow through position)
- **The most important basic skills in Badminton and their uses (Strategies?)**

MYP
Physical & Health Education

Badminton

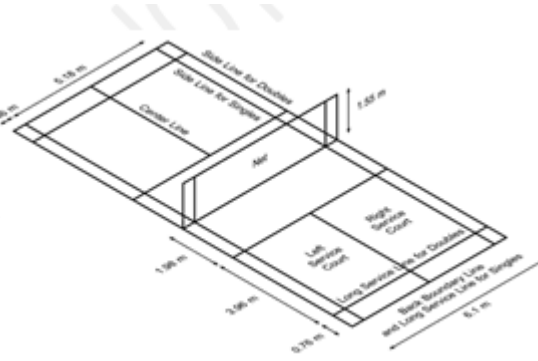

MYP
Physical & Health Education

Hydration & Nutrition

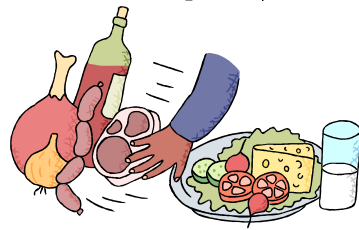

Content Index

- **Hydration**
 - The importance of fluids
 - Feeling thirsty and dehydration level
 - Drinking fluids before exercise
 - Drinking fluids during exercise
 - Rehydration after exercise
- **Hydration and nutrition before, during, and after exercise or competition**
 - Fluids and foods before exercise
 - During exercise
 - After exercise

Final project / Sports performance development



Mathematics, Grade 10

Extra Resources

www.kutasoftware.com

www.mathsisfun.com

- Mathematics can help make sense of the world and allows phenomena to be described in precise terms.
- It also promotes careful analysis and the search for patterns and relationships, skills necessary for success both inside and outside the classroom.

Our focus this year:

- Apply mathematics to authentic real-life situations.
- Perform investigations to discover patterns.
- Prepare students to the DP.
- Use more technology in class.

Topics to be covered this year:

- Quadratic functions
- Sequences and series
- Trigonometry
- Probability and statistics



DISCRETE SCIENCES

Chemistry

- ▶ Energy
- ▶ Chemical kinetics
- ▶ Equilibrium
- ▶ Oxidation and reduction
- ▶ Organic Chemistry
- ▶ Measurements

Biology

- ▶ Adaptations of organisms
- ▶ Cell division, reproduction & inheritance
- ▶ Interaction of species within ecosystem
- ▶ Biotechnology in industry & health

Physics

- Static electricity
- Current electricity
- Magnetism and electromagnetic induction
- Atomic and nuclear physics
- Astrophysics

Grade 10 Integrated Science

Units to be covered this year:

- 1: Human body Systems
- 2: Fuels and Consequences
- 3: Chemical Burns (Acids & Bases)
- 4: Electricity & Magnetism

Extra resources for our keen learners:

<https://www.sciencenewsforstudents.org/sciencejournalforkids.org>



[Scientific Articles](#)

[Lesson Ideas](#)

[For Researchers](#) ▾

[About Us](#) ▾

[Support Us](#)

Hundreds of scientific articles. Written for kids. Approved by scientists.

UNIT 1: FLAT PACK FURNITURE

UNIT 2: TBA

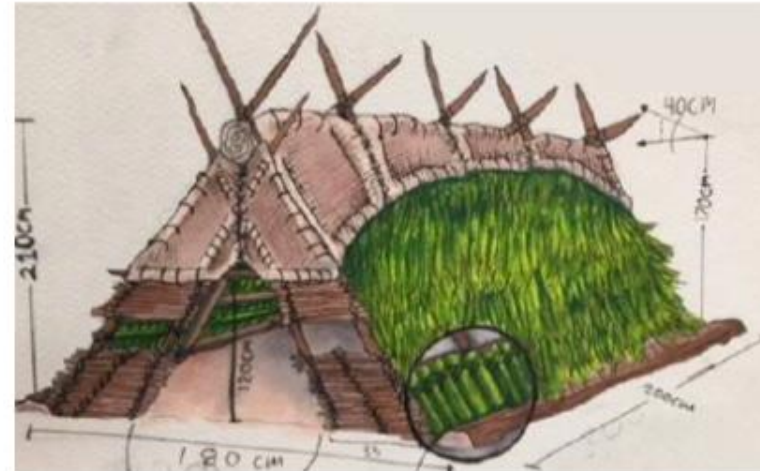

اللغة (أ) اللغة والأدب :

1- وحدة القصة القصيرة- (عناصر القصة القصيرة، حل أسئلة متعلقة بالتحليل، كتابة مقال تحليلي حول قصة خارجية)

2- وحدة الفنون غير الأدبية (المدونة، المنشور، المقابلة...) - نصوص فهم واستيعاب - نصوص استماع.

3- وحدة الرواية عائد إلى حيفا (عناصر الرواية، تحليل اختيارات الكاتب) حل أسئلة متعلقة بالتحليل.

المعايير:

أ- التحليل

ب- التنظيم

ج- إنتاج النص

د- اللغة

Individuals and Societies Mr. Matthew & Ms. Hanin

G10 units:

- Globalisation & Resources (IDU with English)
- Peace-making & Peace-keeping
- Cold War and Cuban Missile Crisis
- Economics and Civil Rights

By the end of the year students will develop the following skills:

- Analytical thinking skills
- Research skills
- Investigation skills
- Awareness of economic, political and historical events that shaped recent history

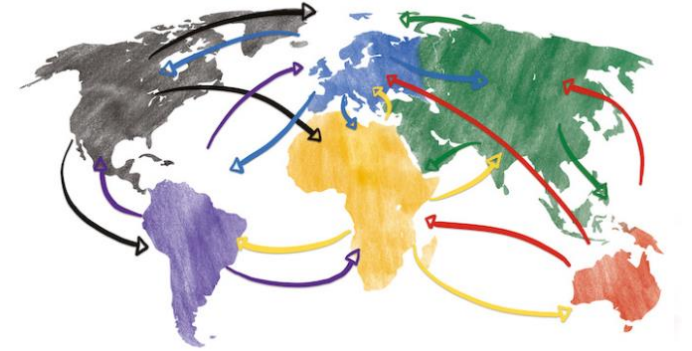

CREATIVE ARTS DEPARTMENT - GRADE 10

- Music: Ms. Obeida
- Visual Arts: Ms. Lubna, Ms. Valerie

Music

Unit 1: Goal Piece: Process and Performance

Unit 2: Between the notes: Analysis

Unit 3: Music Technology

Unit 4: Art speaks out

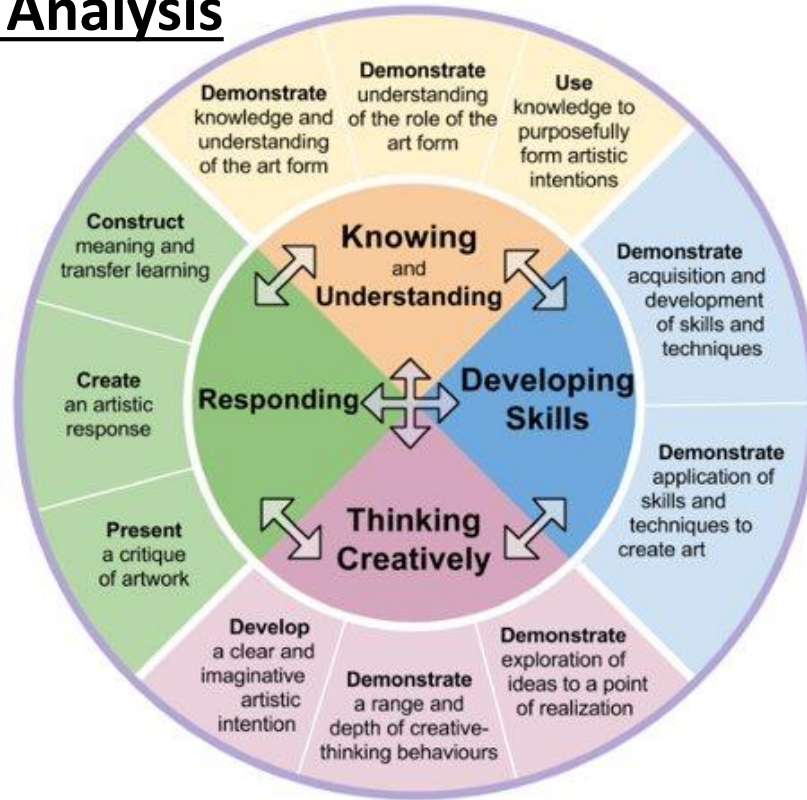

Visual Arts

Unit 1 :Between the lines

Unit 2: Art speaks out



برنامج الأفراد والمجتمعات باللغة العربية

تاريخ بلاد الشام والأردن عبر العصور

- بدء من تاريخ بلاد الشام في العصور القديمة

- ومن ثم تغطية تاريخ بلاد الشام في الحقبة الإسلامية

والعصور الوسطى

- وانتهاء بتاريخ بلاد الشام خلال الحقبة العثمانية ومن ثم العصور

الحديثة التي تمخض عنها ظهور الدولة العربية الحديثة

كيف ولماذا؟

إعطاء الطلبة لتعزيز معرفتهم التاريخية عن الوطن والمنطقة التي يعيشون فيها، إضافة إلى تعزيز مهاراتهم التحليلية والكتابية في اللغة

العربية.

اكتساب اللغة Arabic B

Phase 3+4 : Neven

The units for first semester :

الوحدة الأولى unit 1 : المحافظة على البيئة (the Preservation of the environment) الوحدة الأولى unit 1 : بيئتنا نظيفة (Our environment is clean)
الوحدة الثانية unit 2 : الحيوانات (Animals) الوحدة الثانية unit 2 : فن القصة: (stories)

Phase1+2: Rasha Al-Lahham

الوحدات المطلوبة في الفصل الأول:

المهارات التي سيتم قياسها خلال العام: skills

1-مهارة القراءة (Reading) 2- مهارة الاستماع (Listening) 3- مهارة التحدث (Speaking) 4- مهارة الكتابة (writing)

ENGLISH – LANGUAGE & LITERATURE

Unit 1: Corporate Social Responsibility (IDU with Individuals and Societies)

Unit 2: Of Mice and Men SAA (Service as Action)

Unit 3: Creative Writing

Unit 4: Macbeth, William Shakespeare

G10 Spanish

Identity and culture (self, family, friends; free time and leisure; food and drink and health; festivals and celebrations)

Education and the world of work (school life; future plans; jobs)

The world we live in (the weather; the environment; global issues)

Local area, travel and tourism (house and home; local area; holidays)

Culture and communities (technology and the media; mobile technology; social media)

Assessment tasks:

A (listening)

B (reading)

C+D (speaking)

C+D (writing)

Teacher:

Mr. Ignacio